

1-32 UN - 2A
FOR C-MOUNT
CAMERA

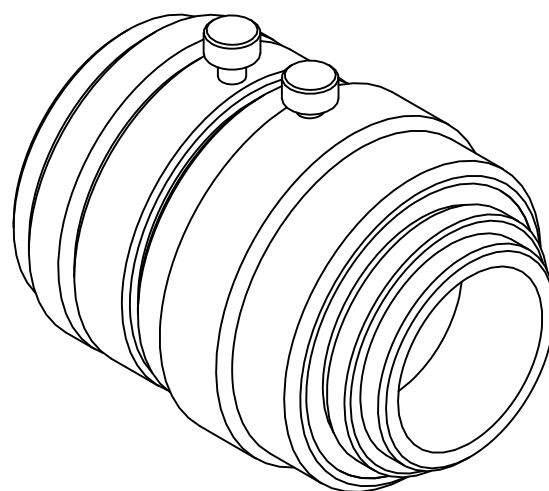

Lens specification - NMV - 12M23

| Specification | Value | 1/2" | 1/3" |
|----------------------------|---------------------|-----------|-----------|
| Focal length | f = 12mm | | |
| Max. diameter (Ratio) | F = 1:1.4 ~ 16 | | |
| Picture Size | 6.6 x 8.8mm | 4.8 x 6.4 | 4.8 x 3.6 |
| Angle Vertical | 26.2 deg. | 21.4 deg. | 16.1 deg. |
| Horizontal | 38.3deg. | 28.3 deg. | 21.4 deg. |
| Diagonal | 46.8 deg. | 35.0 deg. | 26.6 deg. |
| Distortion (TV) | -0.07% | -0.05% | -0.04% |
| Working Dist. - 500mm | 0.025x | | |
| Optical Mag. 400mm | 0.031x | | |
| 300mm | 0.041x | | |
| 200mm | 0.061x | | |
| 100mm | 0.080x | | |
| Minimum Focus Distance | 0.15m | | |
| Flange Back | 17.526mm in air | | |
| Back focus | 11.7mm in air | | |
| Filter Screw Size | m27.0 X 0.5 | | |
| Effective Diameter - Front | 15.8mm dia. | | |
| Rear | 14.1mm dia. | | |
| Mount | C - Mount | | |
| Exit Pupil | - 215mm | | |
| Temperature Range | -10 ~ +45 deg. C | | |
| Strong Temperature Range | -40 ~ +60 deg. C | | |
| Resolution - Center | 100 Line/mm | | |
| Corner | 100 Line/mm | | |
| Weight | 75g | | |

UNLESS OTHERWISE SPECIFIED DIMENSIONS ARE IN INCHES AND INCLUDE CHEMICALLY APPLIED OR PLATED FINISHES

SCALE: 2:1

WEIGHT: See Table

DR: BE

CH:

PROJECT #: E2338

DATE DR: 7/11/2007

THE CONTENTS OF THIS DOCUMENT ARE PROPRIETARY TO NAVITAR. ITS USE IS AUTHORIZED ONLY FOR RESPONDING TO REQUEST FOR QUOTATION OR PERFORMANCE OF WORK FOR NAVITAR

0.0 inch 1.0

0.0 mm 25.0

DO NOT SCALE DRAWING



LENS, 12mm FL, f/1.4, 2/3" MEGAPIXEL

| | | |
|--------------|--------------------|----------|
| SIZE | NMV - 12M23 | REV |
| B | | A |
| SHEET 1 OF 1 | | |