



Iron CLHS 252

Iron CLHS

Small Form Factor, Ruggedized Camera

Innovative Approach

The **Iron CLHS 252** is a compact, high speed, low-cost, low-power global shutter CMOS camera with a CLHS interface which supports 3.15 MP high quality video at rates up to 205.8 fps.

Intelligent Design

Our camera incorporates Pregius's IMX252 global shutter sensor with a 3.45 μ m pixel size. With an extremely compact outline and low-key design, the **Iron** can be fitted into tight spaces. Superior sensor performance allows very low light vision capabilities.

Applications:

- Perimeter vision
- Military/Defense systems
- Low light surveillance
- Special Effects
- Virtual Reality
- 3D

Key Features:

- 3.15 Megapixel up to 205.8 fps
- Monochrome and Color models
- Up to 4.5W power at full rate
- Full image processing feature set
- Optional Pan/Tilt alignment of the sensor
- CLHS X-Protocol 10Gpbs fiber optic interface
- C / CS / EF or DC Auto Iris mounts available
- Full EMVA1288 report
- Full built-in self-test (BIT)
- Full built-in voltage testing
- Customization as per user requirements

Specifications

Feature	Description
Pixel Size	3.45 μm x 3.45 μm
Resolution	2048 (H) x 1536 (V)
Sensor Size	8.9 mm diagonal
Sensor	Sony Pregius IMX252 CMOS sensor
Output Interface	Fiber 10Gbps: CLHS (X-protocol). 10GiGE Vision is available upon request.
Interface Connector	Fiber optic SFP+ module (single mode 1310nm)
Supported SFP+ Modules	<ul style="list-style-type: none"> ▪ Single-mode 1310nm ▪ Multi-mode 850nm ▪ Bidirectional single-mode (single fiber) ▪ CWDM
Output Resolution	8, 10 or 12 bit
Max Frame Rate	205.8 fps @8 bit resolution 112.3 fps @10 bit resolution 112.3 fps @12 bit resolution
Image Acquisition	Continuous / Triggered
Camera Control	GenCam
Electronic Shutter	Global shutter
Sensor Positioning	Full pan/tilt calibration for optical axes (optional)
Monochrome/ Color	Monochrome / Color
Temporal Noise	< 2.2 e ⁻ @25°C
Full Well Charge	9828 e ⁻
Dynamic Range	> 70.8dB @520nm
Signal-to-Noise Ratio (SNR max)	40 dB @520nm
Quantum Efficiency (QE) X FF	> 63% @525nm
Shortest Exposure	10 μs
On Camera Processing	<ul style="list-style-type: none"> ▪ Defect pixel correction ▪ ROI ▪ Frame counter ▪ Flat field / Fixed pattern noise correction ▪ Auto/Manual black level ▪ Auto Exposure/Gain ▪ Auto/Manual White balance ▪ Image flip ▪ LUT ▪ Gain (Analog / Digital) ▪ Binning ▪ Operational Time Counter
GPIO Connection	Two inputs, two outputs, external trigger & strobe controller

Mechanical & Electrical

Feature	Description
Dimensions (including lens mount)	45.8 mm x 45.8 mm x 86.8 mm (Height x Width x Depth)
Lens Mount	C-mount, CS-mount, EF-mount or DC Auto Iris lenses
Weight (without lens)	<180g
Power Input	12V (optional 5 – 36V)
Power Consumption	<4.5W @ 12V DC
Operating Temperature	-40°C to 80°C (-40°C to 70°C for 10GiGE), 20-85% humidity (non-condensing)
Storage Temperature	-40°C to 85°C (-40°C to 75°C for 10GiGE), 10-90% humidity (non-condensing)
Ingress Protection	Optional IP67 (with protective lens tube)
Operational Shock	Tested per MIL-STD-810G Method 516.6, 3-axis Shock 75G
Operational Vibration	Tested per MIL-STD-810G Method 514.6, 3-axis Vibration Category 20

* KAYA Instruments reserves the right to update the data sheet from time to time without prior notice.

General Purpose Input Output

GPIO Pinout – 12 Pin Hirose Connector

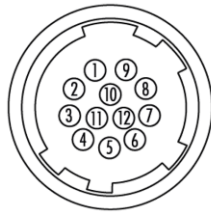

- | | |
|--------------------|-----------------|
| 1. 5 VDC Return | 7. OUT1 (TTL) |
| 2. +5 VDC | 8. IN1 (OPTO) |
| 3. Reserved | 9. IN2 (LVTTTL) |
| 4. Reserved | 10. IN1 RTN |
| 5. OUT2 RTN (OPTO) | 11. IN2 RTN |
| 6. OUT1 RTN | 12. OUT2 (OPTO) |

Absolute Quantum Efficiency

Pregius's IMX252 Mono Spectral Response

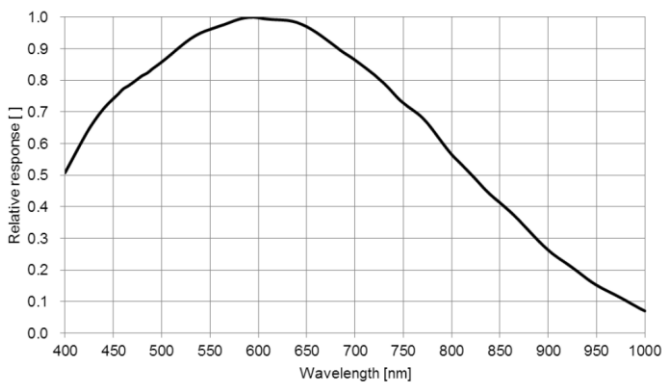

Pregius's IMX252 Color Spectral Response

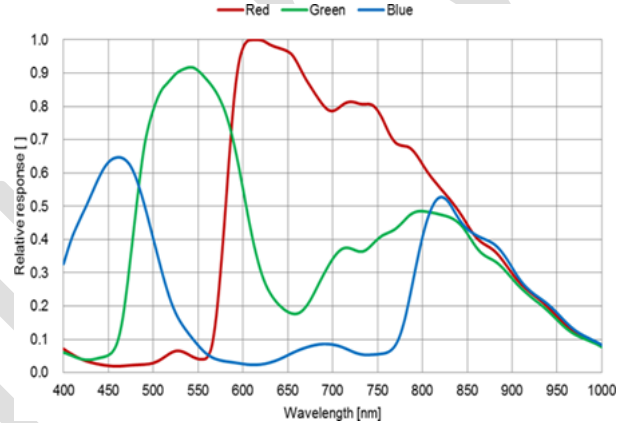

Mechanical Drawings

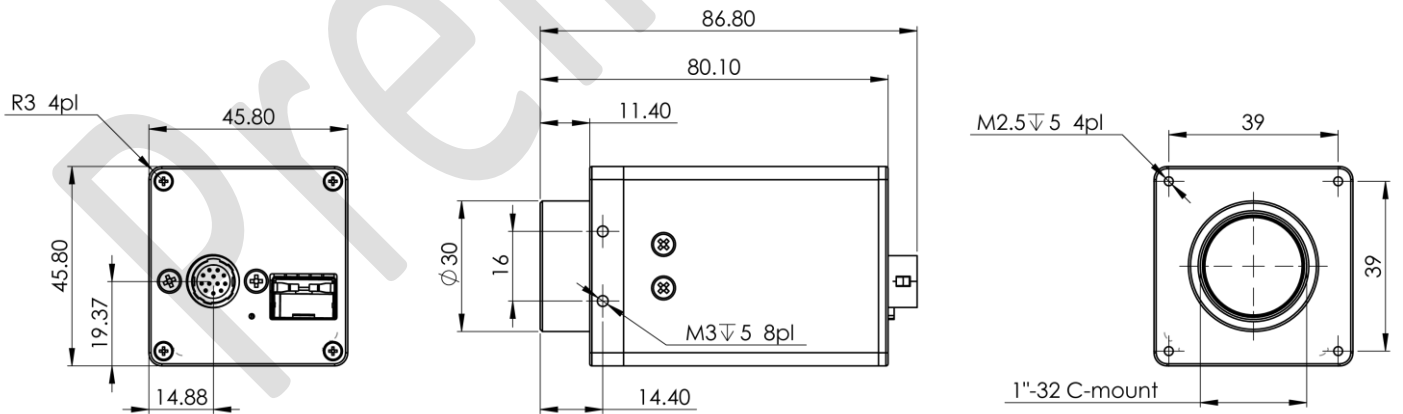

Compatibility

KAYA Instruments creates and maintains compatibility and interfaces for the most common and advanced vision image processing libraries and applications. Major support is available for **MVTec Halcon**, **National Instruments' LabVIEW** and **MathWorks' MATLAB**.

❖ Supported vision standards:



❖ Supported vision libraries:



❖ Supported operating systems:



Please check our website for an up-to-date list of other supported libraries and software package

Contact Us

Please feel free to contact our team with any question or further inquiry at info@kayainstruments.com – we will be happy to provide assistance and consultation.

KAYA Instruments

20 HaMesila St., Nesher 3688520, Israel
POB 25004, Haifa 3125001, Israel

Tel: +972-72-272-3500
Fax: +972-72-272-3511



© 2017 KAYA Instruments, Inc. All rights reserved. KAYA Instruments, the KAYA Instruments Komodo logo, JetCam logo, Predator, Iron and combinations thereof are trademarks of KAYA Instruments, Inc. in the United States and/or other jurisdictions. Microsoft Windows is a registered trademark of Microsoft Corporation. Other names are for informational purposes only and may be trademarks of their respective owners. KAYA Instruments is not liable for harm or damage incurred by information contained in this document

